

Double Action Bodymaker

Serving the can making industry.....worldwide.

OKL Can Line Inc.

11235 Sebring Drive

Cincinnati, OH

45240

USA

Phone: + 1 513 825 1655

Fax: + 1 513 825 1948

WWW.OKLcan.com

E-mail: Sales@oklcan.com

OKL has designed its DWI Bodymaker to be the best of its kind.

For nearly 25 years, OKL has repaired and improved existing can-making machines. However, the company now manufactures new Bodymakers. Plus, because of its industry knowledge, OKL has given the highest priority to such machine-performance aspects as speed, maintenance, resource consumption, personnel safety and housekeeping.



- ◆ Use of composite-bearing materials allow use of a fraction of typical oil resulting in a 60% savings.
- ◆ Reduced air consumption by replacing "air assist" cup-feed with Servo-driven Rotary cup-feed.
- ◆ Employing the Air-bag eliminates air and oil consumption associated with the Air-cylinder.
- ◆ Additional, high-pressure pump stations that consume power & generate heat are not required.
- ◆ The new Frame has access panels which are o-ring sealed and guarded. The frame also includes large and conveniently located service points to accommodate routine maintenance and set-up procedures.
- ◆ OKL's guard package is CE approved



Double Action Bodymaker

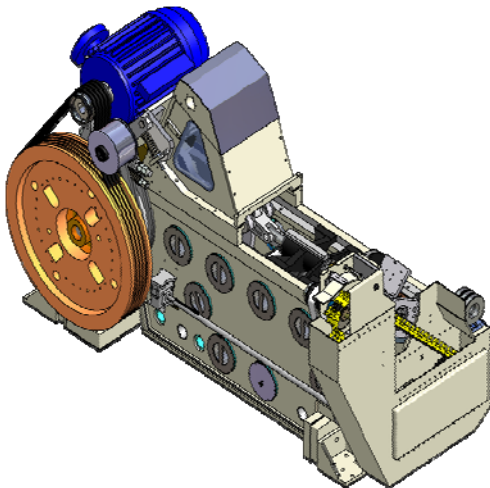
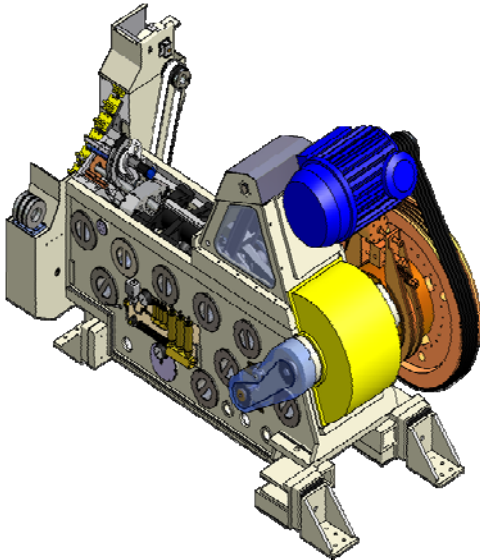

Style Number:	Stroke Primary	Stroke Redraw	Mfg. Rate	Length of Can Body
DA185-20	18.5"	2.0"	380	413
DA210-20	21.0"	2.0"	340	504
DA210-25	21.0"	2.5"	300	504
DA240-20	24.0"	2.0"	315	603
DA240-25	24.0"	2.5"	300	603
DA265-25	26.5"	2.5"	275	710

Special Features (developed or exclusive to OKL) included:

- ◆ Frame, welded steel/filled-vibration/noise reducing
- ◆ Heavy-Duty Crankshafts (HD-CS)
- ◆ Aluminum Parallel Motion Assembly (APMA)
- ◆ Linear Guidance System (LGS)
- ◆ Servo-Driven Rotary Cup Feed (SD-RCF)
- ◆ Stainless-Steel Guard System (S/S-GS)
- ◆ Aluminum Redraw Idler (ARDI)
- ◆ Composite Redraw Carriage Bushings (with Coolant Lubricant)

Other Features included:

- ◆ Optical encoder electronic timing
- ◆ Machine lubrication, injector and/or Trabon
- ◆ Tool housing, top-loading (choose from fixed, floating or adjustable)
- ◆ Clutch/brake (choose from disk or drum)
- ◆ Air strip (choose from electronic or rotary mechanical)
- ◆ Floor mounting, vibration isolation

Specifications/overall dimensions:

175" (length) x 77" (wide) x 96" (height)

Weight:

23,000 lbs.

Serving the can making industry.....worldwide.

OKL Can Line, Inc.

11235 Sebring Drive
Cincinnati, OH
45240
USA

Phone: + 1 513 825 1655

Fax: + 1 513 825 1948

WWW.OKLcan.com

E-mail: Sales@oklcan.com

